

THANK YOU FOR CHOOSING OUR QUALITY PRODUCTS

In order to enjoy your mannequin for a long time, please pay attention to our care and handling recommendations.

Please note: Since this style is part of an extensive sports collection, the bases are optimised for each pose to offer the best stability.

WHAT'S IN THE BOX:

1. a. base plate
b. calf pin connector
c. calf pin
2. small hexkey (offered if over time the base connector screws would come loose and need to be tightened again)
3. big hexkey (offered to set the tension of waist and leg fitting if required over time)
4. protection gloves
5. upper body part
6. arms
7. hands
8. leg (if both legs are not connected)*
9. lower body part

Tip: We highly recommend you to mark each part of the mannequin, base and connectors in a non-visible area like the connection ports of the torso, legs, arms and hands to keep all the components together in case of future disassembly or reassembly.

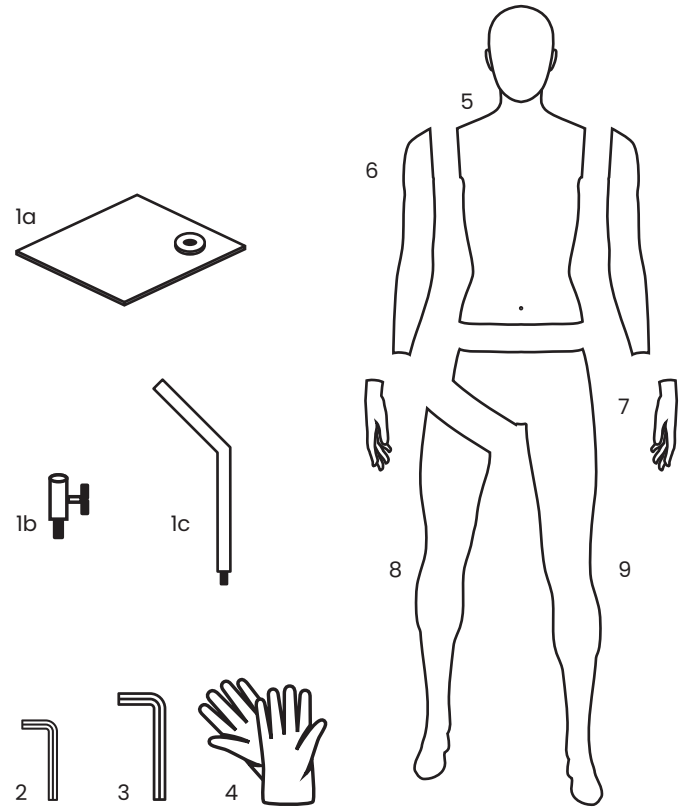

ASSEMBLING INSTRUCTIONS:

STEP 1: Safety

Please take off all jewellery and put on gloves.

STEP 2: Opening the box

Use a box cutter / scissors to cut the straps, box and protective foam bags.

ATTENTION! Don't cut too deep to avoid damage on any of the product components. Take all the parts out of the box one by one and place them on a soft surface.

STEP 3: Install the base on the floor

3a. Place the base on the floor and screw in the calf pin connector (1b) to the base plate (1a).
Make sure to tighten well.

3b. Insert the calf pin (1c) into the calf pin connector (1b) with top of calf pin in the centre of the base and tighten the butterfly screw.

3a. Place the base on the floor and screw in the calf pin connector (1b) to the base plate (1a).
Make sure to tighten well.

3b. Insert the calf pin (1c) into the calf pin connector (1b) with top of calf pin in the centre of the base and tighten the butterfly screw.

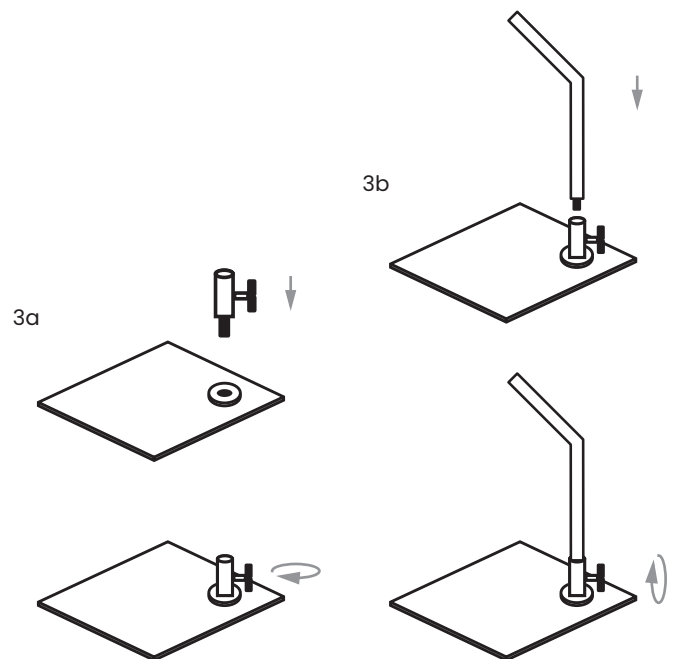

continues on the other side →

← starts on the other side

STEP 4: Install the legs

4a. Place the lower body part feet up on a soft surface, now you can easily connect the separate leg onto the hip part thanks to the magnetic fitting.

Tip: This is the perfect position to dress trousers and put shoes on.

4b. Turn the legs again and position the legs on the base. Ensure that the base is stable and on a flat surface to avoid problems. Once the legs are positioned onto the base, please tighten the hand screw of the thigh pin protector to keep the legs in place onto the base.

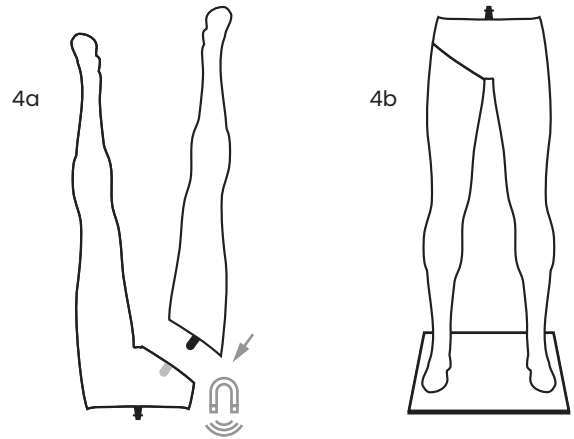

STEP 5: Install the torso

5 Place the torso on the legs, at 90° then rotate the torso into it's final position.

Tip: Only if necessary you can use the Allen key provided to adjust the tightness of the torso. Clockwise will tighten and counter-clockwise will loosen the connection.

Tip: This is a good time to dress tops.

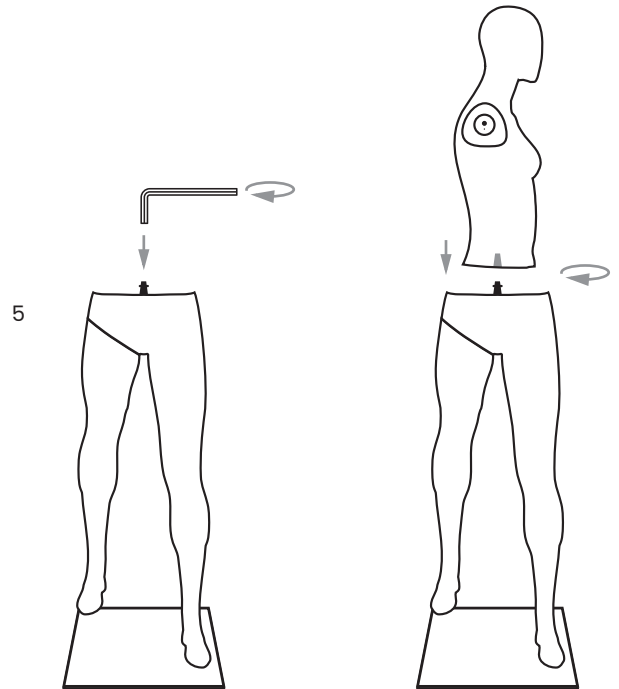

STEP 6: Install arms & hands

6a. Connect the arms onto the torso. Once the arms are connected, they can be rotated front and back to find that perfect position.

6b. Connect the hands inserting them and turning until they reach their final position.

Tip: Only connect the hands once the mannequin is completely dressed.

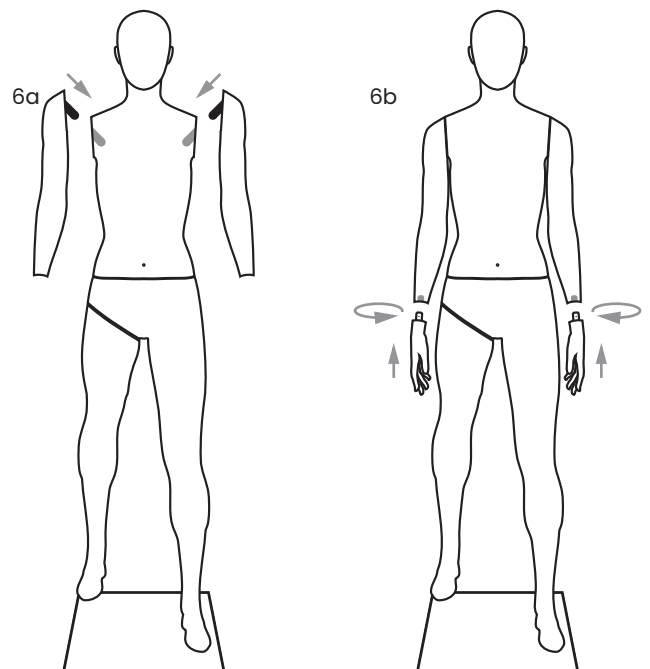

HANDLING & CARE GUIDELINES:

We recommend to (dis)assemble the mannequin on a soft and flat surface to avoid any damage.

Please always remove any jewellery before handling a mannequin to avoid scratches. We recommend using the provided gloves to avoid marks and stains.

While dressing, one often inserts the arms through the neck opening of the garment. Please ensure that the hook is opposite from the chest and rotate the arm only when the position of the hook is in front of the insert in the body. This way you avoid damaging the paint on the mannequin with the hook.

In order to clean the mannequin, please use a slightly moistened cloth with detergent that has been diluted with water. Minor stains can be removed with an eraser.